

CAR CALIBRATION KIT

CAR-CAL-KIT



According to

ISO 7637-2:2011

ISO 16750-2

General:

In accordance with the pulse verification requirements given in Annex C of ISO 7637-2:2011 and Annex A of ISO 16750-2:2012, test pulses generated by automotive transient generators need to be verified both under no-load (open circuit verification) and loaded conditions with specified loads.

The values of the load resistors is specified and are equal to the generator's internal source impedance defined for the corresponding test pulse.

The CAR-CAL-KIT is a resistor box containing all load resistors required to verify CAR pulse and load dump generators according to international standards and manufacturer requirements.

Operation:

The CAR-CAL-KIT verification box is plugged into the outputs of the transient generator. The required load resistor is selected by a 4 mm bridge connector.

The waveform across the load resistor is best measured by a 100:1 voltage probe with sufficient bandwidth and voltage capability. Hilo-Test recommends a bandwidth of 20MHz minimum and a voltage measuring capability of 1000V.

Schema

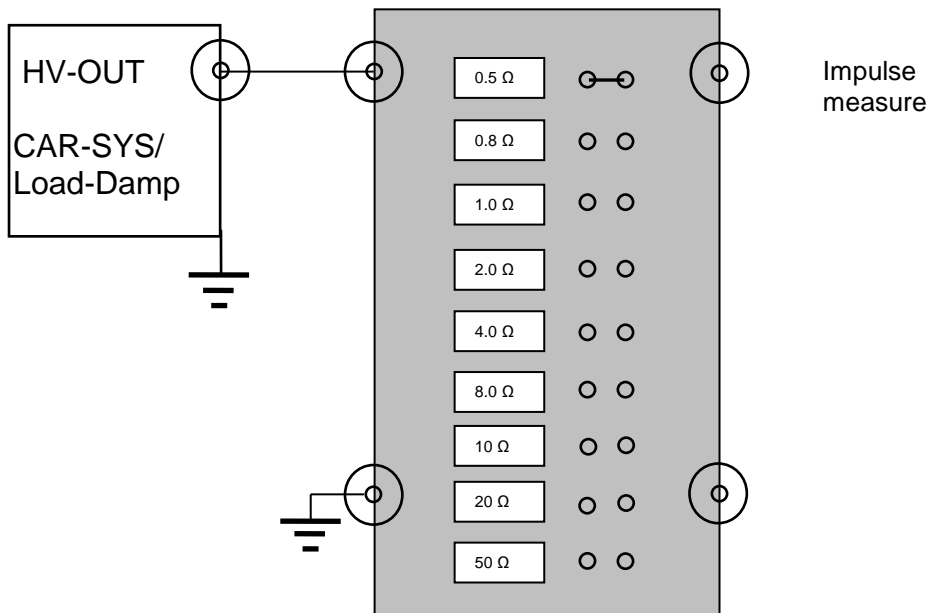

Technical specification	CAR-CAL-KIT
According to Standards	ISO 7637-2:2011 ISO 16750-2
Built-in resistor values, selectable	0.5 / 0.8 / 1 / 2 / 4 / 8 / 10 / 20 / 50 Ω
Resistor tolerance	±1%
Connectors	4mm safety lab connectors
Fits to all Hilo-Test automotive CAR generators	